

Multilayer Chip Inductors(Coils)

For General Signals/Decoupling

MLZ (Magnetic Shielded) series

Type:	MLZ1005W	[0402 inch]* (For Current)
	MLZ1608	[0603 inch] (For Current)
	MLZ2012-H	[0805 inch] (For Current)
	MLZ2012	[0805 inch] (For Current)

* Dimensions Code JIS[EIA]

Issue date: April 2011

- All specifications are subject to change without notice.
 - Conformity to RoHS Directive: This means that, in conformity with EU Directive 2002/95/EC, lead, cadmium, mercury, hexavalent chromium, and specific bromine-based flame retardants, PBB and PBDE, have not been used, except for exempted applications.
-

SMD Inductors(Coils) For Power Line(Multilayer, Magnetic Shielded)

Conformity to RoHS Directive

MLZ Series MLZ1005W

The MLZ Series is a new line of multilayer choke coils for decoupling with the industry's best DC superimposition characteristics and lowest DC resistance*. TDK has developed this coil using its proprietary ferrite material technique and dense electrodes.

The MLZ Series exerts an excellent effect mainly on the decoupling of power circuits. It also exerts an effect on audio lines because of its low DC resistance.

The MLZ1005 series is now available in addition to the MLZ1608/2012 series.

* The MLZ Series was regarded as having the industry's best DC superimposition characteristics and lowest DC resistance according to research conducted in September 2010.

FEATURES

- MLZ1005 series products have the best DC superimposition characteristics in the industry.
- Magnetically sealed configuration allowing for high-density mounting.
- Does not contain lead and is compatible with lead-free soldering.
- It is a product conforming to RoHS directive.

APPLICATIONS

Modules such as digital cellular phone and camera module, Netbooks, note PCs, DSCs, DVCs, video games, portable memory audio devices, navigation systems, PNDs, TVs, W-LANs, solid state drives

SPECIFICATIONS

Operating temperature range	-55 to +125°C [Including self-temperature rise]
Storage temperature range	-55 to +125°C

RECOMMENDED SOLDERING CONDITION REFLOW SOLDERING

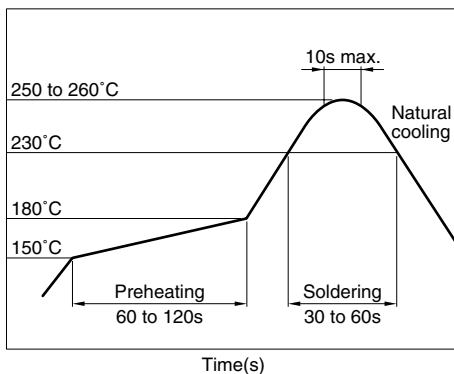

• Conformity to RoHS Directive: This means that, in conformity with EU Directive 2002/95/EC, lead, cadmium, mercury, hexavalent chromium, and specific bromine-based flame retardants, PBB and PBDE, have not been used, except for exempted applications.

• Please contact our Sales office when your application is considered the following:
The device's failure or malfunction may directly endanger human life (e.g. application for automobile/aircraft/medical/nuclear power devices, etc.)

• All specifications are subject to change without notice.

PRODUCT IDENTIFICATION

MLZ	1005	M	1R0	W	T
(1)	(2)	(3)	(4)	(5)	(6)

(1) Series name

(2) Dimensions L×W

1005	1.0×0.5×0.5mm
------	---------------

(3) Management symbol

(4) Inductance value

R47	0.47μH
1R0	1.0μH

(5) Product classification code

W	IDC-UP
---	--------

(6) Packaging style

T	Taping [reel]
---	---------------

PACKAGING STYLE AND QUANTITIES

Packaging style	Quantity
Taping	10000 pieces/reel

HANDLING AND PRECAUTIONS

- Before soldering, be sure to preheat components.
The preheating temperature should be set so that the temperature difference between the solder temperature and product temperature does not exceed 150°C.
- After mounting components onto the printed circuit board, do not apply stress through board bending or mishandling.
- The inductance value may change due to magnetic saturation if the current exceeds the rated maximum.
- Do not expose the inductors to stray magnetic fields.
- Avoid static electricity discharge during handling.
- When hand soldering, apply the soldering iron to the printed circuit board only. Temperature of the iron tip should not exceed 350°C. Soldering time should not exceed 3 seconds.

SHAPES AND DIMENSIONS/RECOMMENDED PC BOARD PATTERN

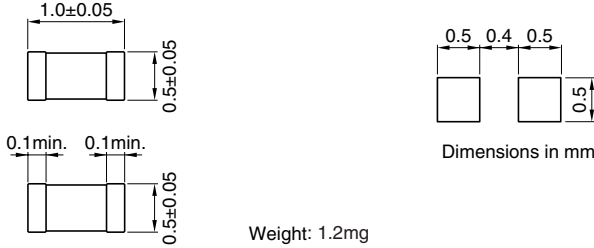

ELECTRICAL CHARACTERISTICS

Classification	Part No.	Inductance (μH)	Inductance tolerance	Test frequency L (MHz)	Test current L (mA)	Self-resonant frequency (MHz)typ.	DC resistance (Ω)±30%	Rated current*1 (mA)	Rated current*2 (mA)
IDC-UP	MLZ1005MR47WT	0.47	±20%	2	0.1	260	0.20	120	500
	MLZ1005MR68WT	0.68	±20%	2	0.1	210	0.30	110	450
	MLZ1005M1R0WT	1.00	±20%	2	0.1	170	0.35	100	450
	MLZ1005M1R5WT	1.50	±20%	2	0.1	140	0.50	80	350
	MLZ1005M2R2WT	2.20	±20%	2	0.1	120	0.55	60	350

*1 Current assumed when inductance ratio has decreased by 50% max..

*2 Current assumed when temperature has risen to 20°C max. (reference value). The maximum operating temperature at this time is 105°C.

- Test equipment
Inductance: Ag-4294A+16034G

TYPICAL ELECTRICAL CHARACTERISTICS

INDUCTANCE vs. FREQUENCY CHARACTERISTICS

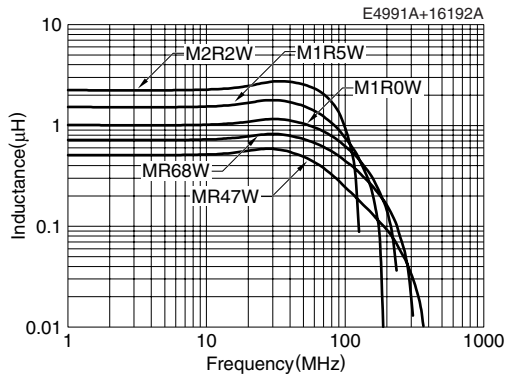

IMPEDANCE vs. FREQUENCY CHARACTERISTICS

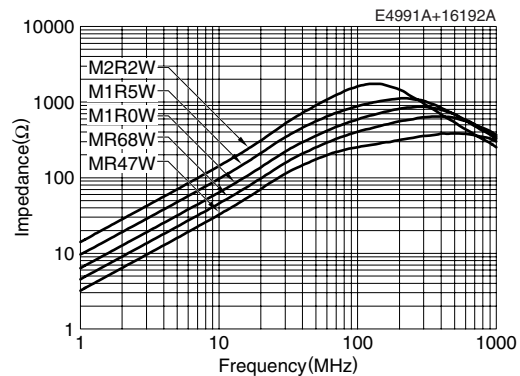

INDUCTANCE CHANGE vs. DC SUPERPOSITION CHARACTERISTICS

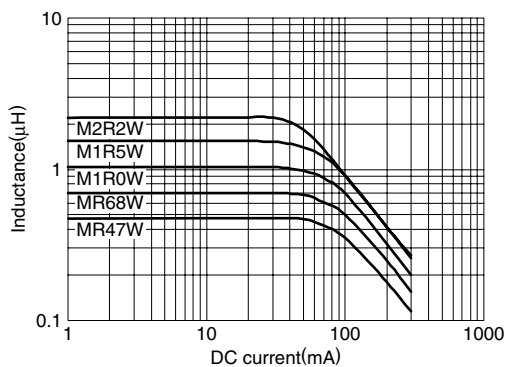

TEMPERATURE CHARACTERISTICS

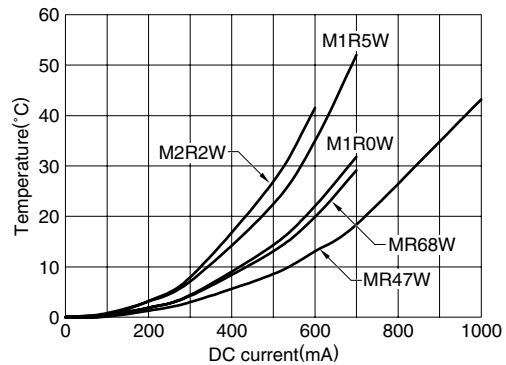

• All specifications are subject to change without notice.

PACKAGING STYLES
REEL DIMENSIONS

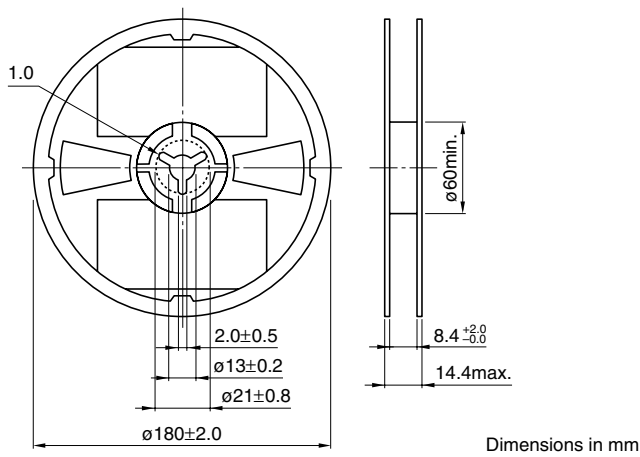

TAPE DIMENSIONS

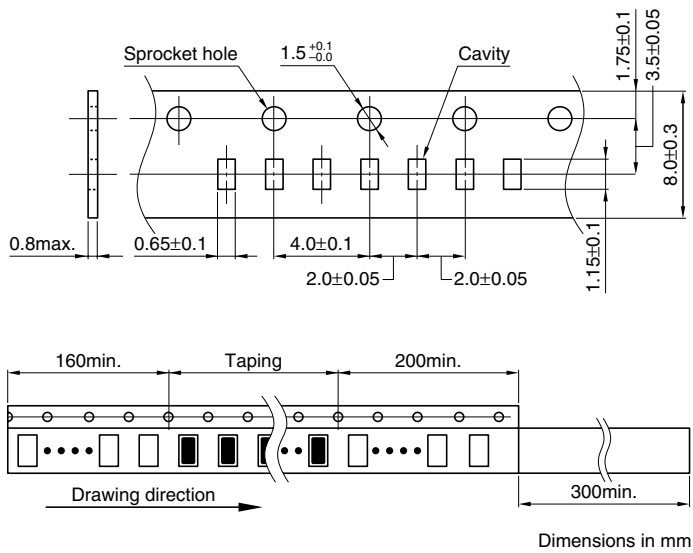

• All specifications are subject to change without notice.

SMD Inductors(Coils) For Power Line(Multilayer, Magnetic Shielded)

Conformity to RoHS Directive

MLZ Series MLZ1608

The MLZ Series is a line of multilayer choke coils for decoupling power circuits.

The MLZ1608-W Series, a line of the MLZ Series, has increased its DC superimposition characteristics by up to 225%* compared with existing products through the use of TDK's proprietary ferrite material technology.

Also available is the MLZ1608-L Series. This series has lowered its resistance by up to 40% compared with existing products through the adoption of a new ferrite material and dense electrodes. This series includes the E3 Series, which handles 1.0 to 10 μ H, hence it is extremely useful in the power-supply design of low-voltage circuits.

FEATURES

- The W Series (IDC UP type) is a line of products that have achieved the industry's best* DC superimposition characteristics.
* According to research conducted in August 2010.
- The L Series (Low-resistance type) has lowered its resistance by up to 40% compared with existing products.
- The D Series (High frequency type) is a line of decoupling coil products for high frequencies. It can handle higher noise frequencies.

APPLICATIONS

Modules such as digital cellular phone and camera module, Netbooks, note PCs, DSCs, DVCs, video games, portable memory audio devices, navigation systems, PNDs, TVs, W-LANs, solid state drives

SPECIFICATIONS

Operating temperature range	-55 to +125°C [including its own temperature rise]
Storage temperature range	-55 to +125°C

RECOMMENDED SOLDERING CONDITION REFLOW SOLDERING

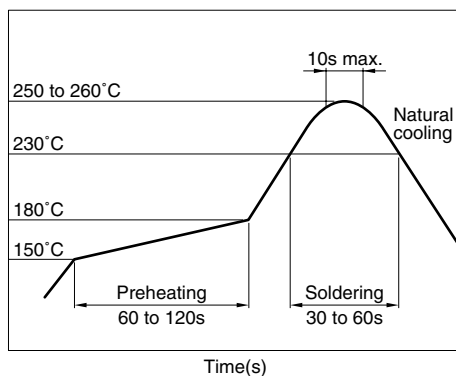

- Conformity to RoHS Directive: This means that, in conformity with EU Directive 2002/95/EC, lead, cadmium, mercury, hexavalent chromium, and specific bromine-based flame retardants, PBB and PBDE, have not been used, except for exempted applications.

- Please contact our Sales office when your application is considered the following:
The device's failure or malfunction may directly endanger human life (e.g. application for automobile/aircraft/medical/nuclear power devices, etc.)

- All specifications are subject to change without notice.

PRODUCT IDENTIFICATION

MLZ	1608	A	1R0	W	T
(1)	(2)	(3)	(4)	(5)	(6)

(1) Series name

(2) Dimensions L×W

1608	1.6×0.8mm
------	-----------

(3) Management symbol

(4) Inductance value

R10	0.1 μ H
1R0	1.0 μ H
100	10.0 μ H

(5) Types of characteristics

D	High frequency type
W	IDC-UP type
L	Low-resistance type

(6) Packaging style

T	Taping [reel]
---	---------------

PACKAGING STYLE AND QUANTITIES

Packaging style	Quantity
Taping	4000 pieces/reel

HANDLING AND PRECAUTIONS

- Before soldering, be sure to preheat components.
The preheating temperature should be set so that the temperature difference between the solder temperature and product temperature does not exceed 150°C.
- After mounting components onto the printed circuit board, do not apply stress through board bending or mishandling.
- The inductance value may change due to magnetic saturation if the current exceeds the rated maximum.
- Do not expose the inductors to stray magnetic fields.
- Avoid static electricity discharge during handling.
- When hand soldering, apply the soldering iron to the printed circuit board only. Temperature of the iron tip should not exceed 350°C. Soldering time should not exceed 3 seconds.

SHAPES AND DIMENSIONS/RECOMMENDED PC BOARD PATTERN

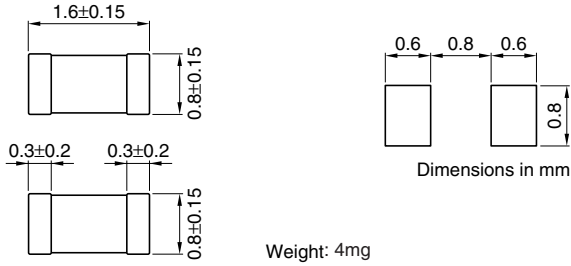

ELECTRICAL CHARACTERISTICS

Classification	Part No.	Inductance (μH)	Inductance tolerance	Test frequency L (MHz)	Test current L (mA)	Self-resonant frequency (MHz)typ.	DC resistance (Ω)±30%	Rated current*1 (mA)	Rated current*2 (mA)
High frequency type	MLZ1608DR10DT	0.10	±20%	25	1.0	600	0.14	700	850
	MLZ1608DR22DT	0.22	±20%	25	1.0	400	0.27	550	600
	MLZ1608DR47DT	0.47	±20%	25	1.0	260	0.42	400	500
IDC-UP type	MLZ1608A1R0WT	1.00	±20%	10	1.0	170	0.15	190	600
	MLZ1608A2R2WT	2.20	±20%	10	1.0	120	0.25	130	500
	MLZ1608M4R7WT	4.70	±20%	2	0.1	80	0.50	120	350
Low-resistance type	MLZ1608M100WT	10.0	±20%	2	0.1	50	1.05	90	250
	MLZ1608N1R0LT	1.00	±20%	2	0.1	170	0.11	140	700
	MLZ1608N2R2LT	2.20	±20%	2	0.1	120	0.18	110	500
	MLZ1608N4R7LT	4.70	±20%	2	0.1	80	0.32	80	400
	MLZ1608N100LT	10.0	±20%	2	0.1	50	0.60	60	300

*1 Current assumed when inductance ratio has decreased by 50% max..

*2 Current assumed when temperature has risen to 20°C max. (reference value). The maximum operating temperature at this time is 105°C.

• Test equipment

Inductance: Ag-4294A+16034G

TYPICAL ELECTRICAL CHARACTERISTICS

INDUCTANCE vs. FREQUENCY CHARACTERISTICS

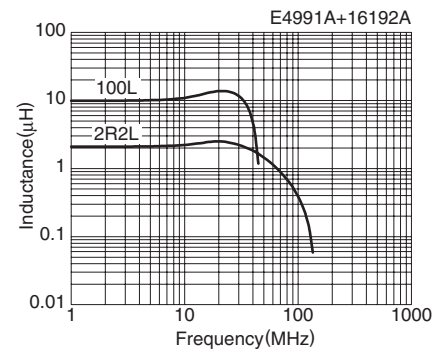
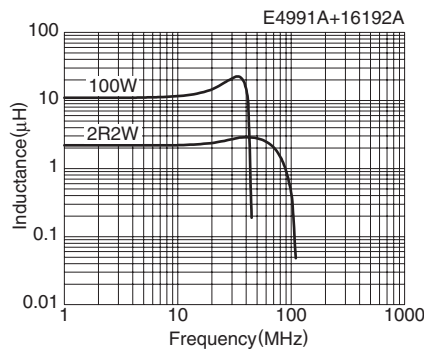
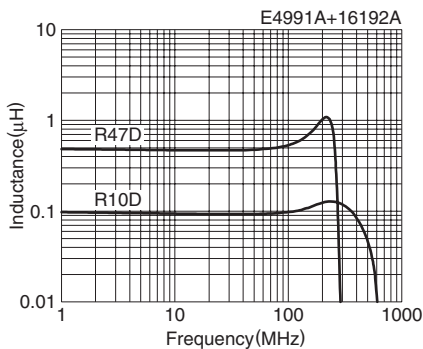

IMPEDANCE vs. FREQUENCY CHARACTERISTICS

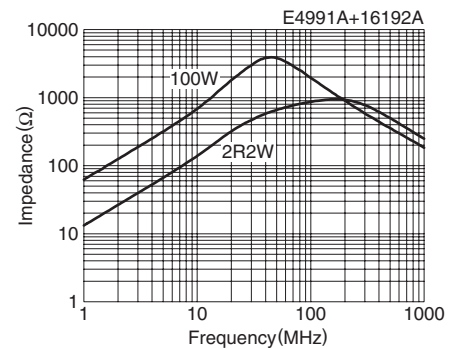
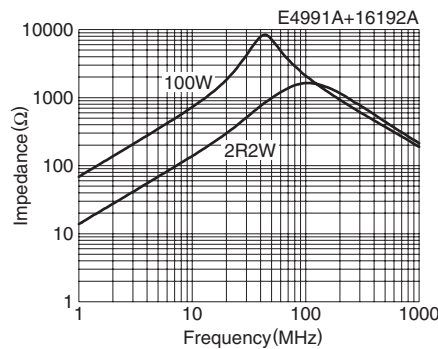
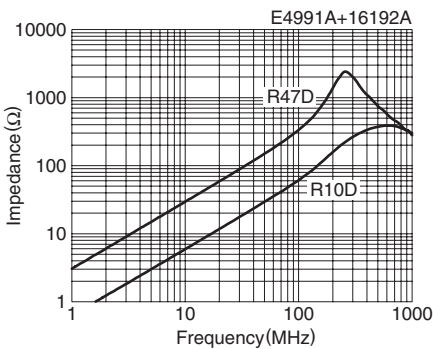

• All specifications are subject to change without notice.

TYPICAL ELECTRICAL CHARACTERISTICS

INDUCTANCE CHANGE vs. DC SUPERPOSITION CHARACTERISTICS

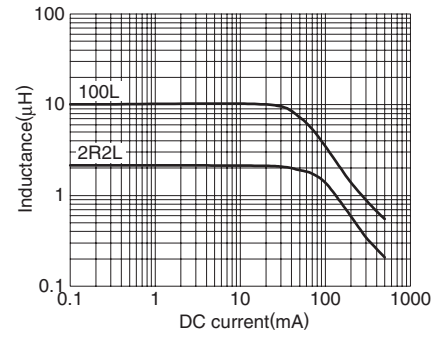
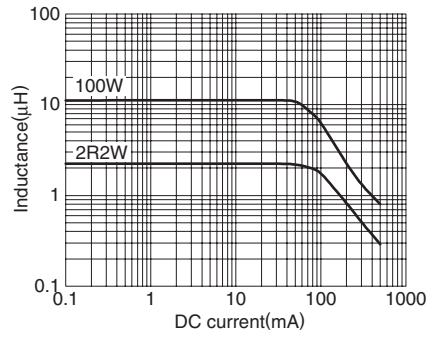
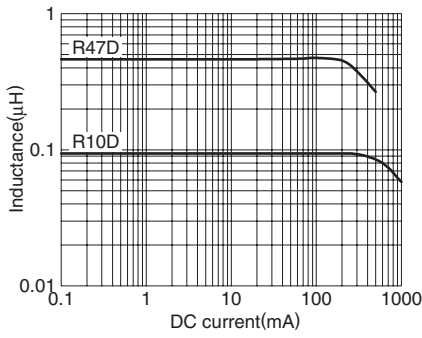

TEMPERATURE CHARACTERISTICS

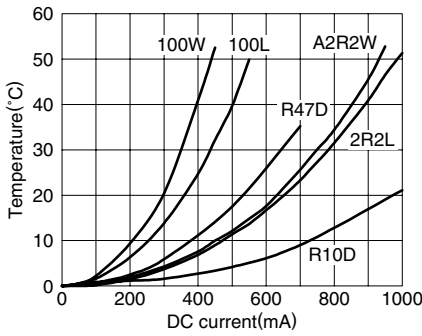

PACKAGING STYLES

REEL DIMENSIONS

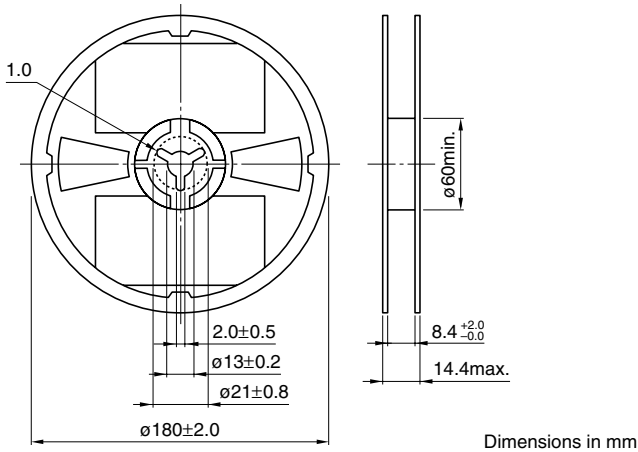

Dimensions in mm

TAPE DIMENSIONS

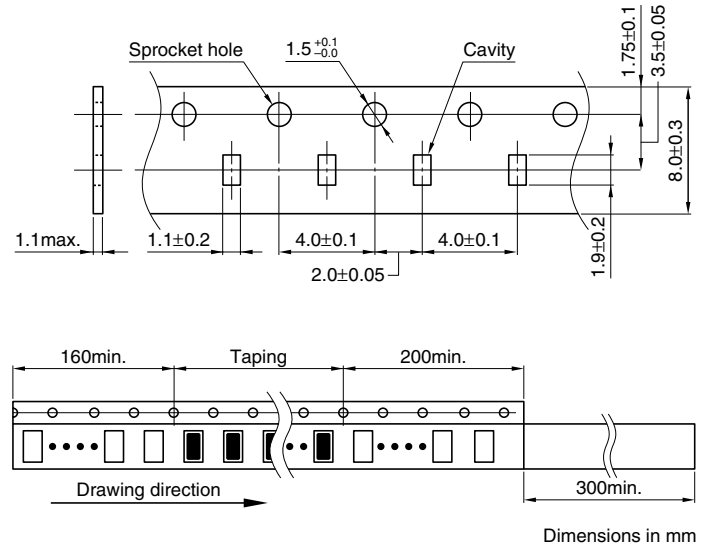

Dimensions in mm

• All specifications are subject to change without notice.

SMD Inductors(Coils) For Power Line(Multilayer, Magnetic Shielded)

Conformity to RoHS Directive

MLZ Series MLZ2012-H

The MLZ-H Series includes multilayer choke coils for decoupling power circuits.

TDK developed ferrite material, which has improved DC superimposition characteristics, allowing for the rated current to be equivalent to the wound coil. The DC superimposition characteristics of this series have been improved by up to 250% over the MLZ-W Series, which previously was in the top class in the industry. In addition, low ohmic electrodes are used making it possible to be compatible with large currents equivalent to the wound coil.

FEATURES

- Improved by up to 250% for large currents over the MLZ-W Series, which was previously in the top class in the industry.
- Magnetically sealed configuration allowing for high-density mounting.
- Does not contain lead and is compatible with lead-free soldering.
- It is a product conforming to RoHS directive.

APPLICATIONS

Decoupling coil for power lines of DSCs, DVCs, PCs, TVs, etc.

SPECIFICATIONS

Operating temperature range	-55 to +125°C [including its own temperature rise]
Storage temperature range	-55 to +125°C

RECOMMENDED SOLDERING CONDITION

REFLOW SOLDERING

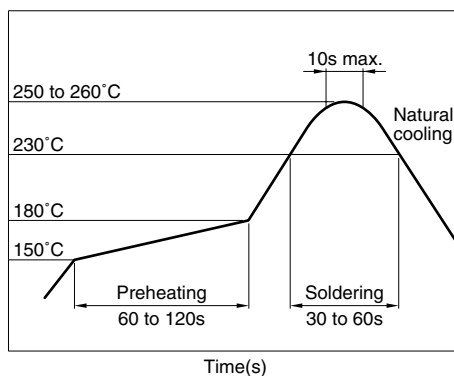

PRODUCT IDENTIFICATION

MLZ	2012	M	100	H	T
(1)	(2)	(3)	(4)	(5)	(6)

(1) Series name

(2) Dimensions L×W

2012	2.0×1.25×1.25mm
------	-----------------

(3) Management symbol

(4) Inductance value

1R0	1.0 μH
100	10.0 μH

(5) Product classification code

H	Super High-current
---	--------------------

(6) Packaging style

T	Taping [reel]
---	---------------

PACKAGING STYLE AND QUANTITIES

Packaging style	Quantity
Taping	2000 pieces/reel

HANDLING AND PRECAUTIONS

- Before soldering, be sure to preheat components. The preheating temperature should be set so that the temperature difference between the solder temperature and product temperature does not exceed 150°C.
- After mounting components onto the printed circuit board, do not apply stress through board bending or mishandling.
- The inductance value may change due to magnetic saturation if the current exceeds the rated maximum.
- Do not expose the inductors to stray magnetic fields.
- Avoid static electricity discharge during handling.
- When hand soldering, apply the soldering iron to the printed circuit board only. Temperature of the iron tip should not exceed 350°C. Soldering time should not exceed 3 seconds.

• Conformity to RoHS Directive: This means that, in conformity with EU Directive 2002/95/EC, lead, cadmium, mercury, hexavalent chromium, and specific bromine-based flame retardants, PBB and PBDE, have not been used, except for exempted applications.

• Please contact our Sales office when your application is considered the following:
The device's failure or malfunction may directly endanger human life (e.g. application for automobile/aircraft/medical/nuclear power devices, etc.)

• All specifications are subject to change without notice.

SHAPES AND DIMENSIONS/RECOMMENDED PC BOARD PATTERN

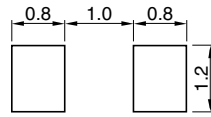
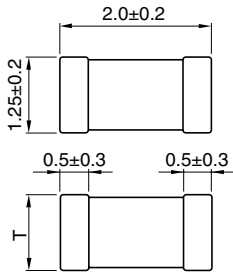

Dimensions in mm



T(Thickness)	Weight(mg)
1.25±0.2	14

ELECTRICAL CHARACTERISTICS

Part No.	Inductance (μH)	Inductance tolerance	Test frequency L (MHz)	Test current L (mA)	Self-resonant frequency (MHz)typ.	DC resistance (Ω)±30%	Rated current*1 (mA)	Rated current*2 (mA)
MLZ2012M1R0HT	1.0	±20%	2	0.1	150	0.10	700	800
MLZ2012M2R2HT	2.2	±20%	2	0.1	100	0.16	400	600
MLZ2012M4R7HT	4.7	±20%	2	0.1	60	0.34	300	400
MLZ2012M100HT	10	±20%	2	0.1	40	0.68	200	300

*1 Current assumed when inductance ratio has decreased by 50% max..

*2 Current assumed when temperature has risen to 20°C max. (reference value). The maximum operating temperature at this time is 105°C.

• Test equipment

Inductance: Ag-4294A+16034G

TYPICAL ELECTRICAL CHARACTERISTICS

INDUCTANCE vs. FREQUENCY CHARACTERISTICS

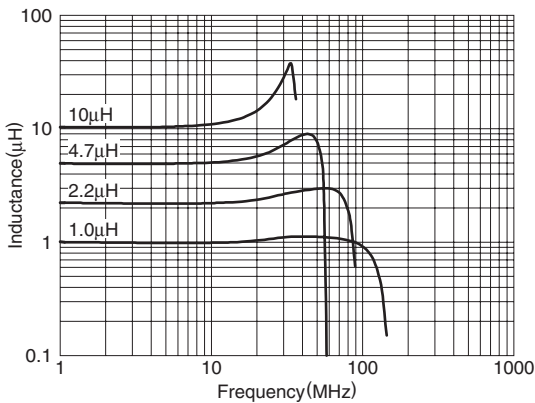

IMPEDANCE vs. FREQUENCY CHARACTERISTICS

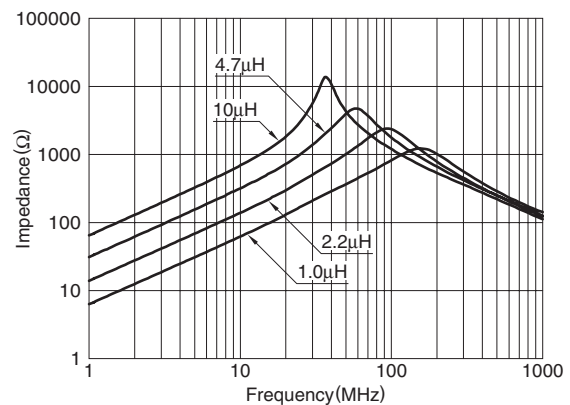

INDUCTANCE CHANGE vs. DC SUPERPOSITION CHARACTERISTICS

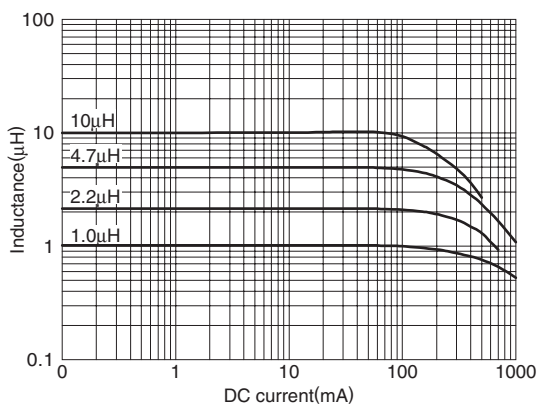

TEMPERATURE CHARACTERISTICS

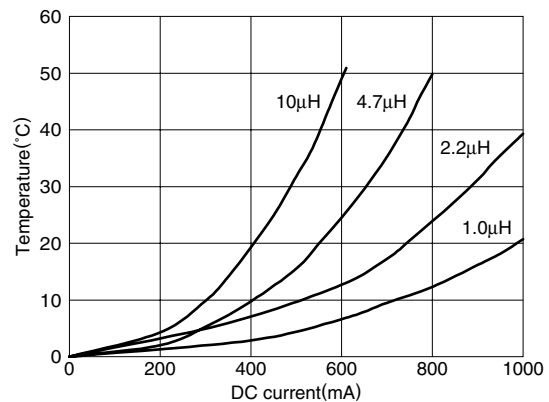

• All specifications are subject to change without notice.

PACKAGING STYLES

REEL DIMENSIONS

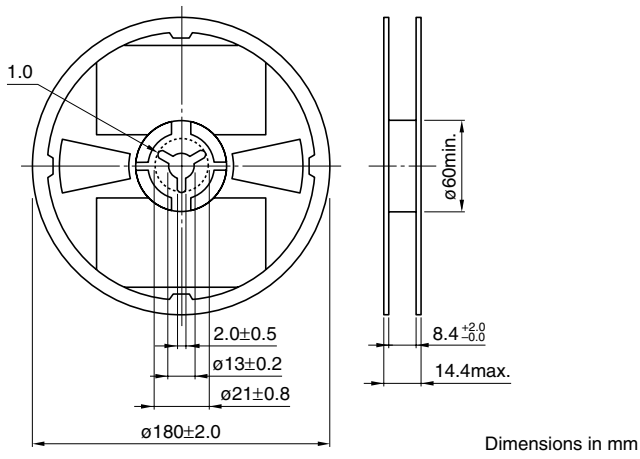

TAPE DIMENSIONS

t=1.25mm

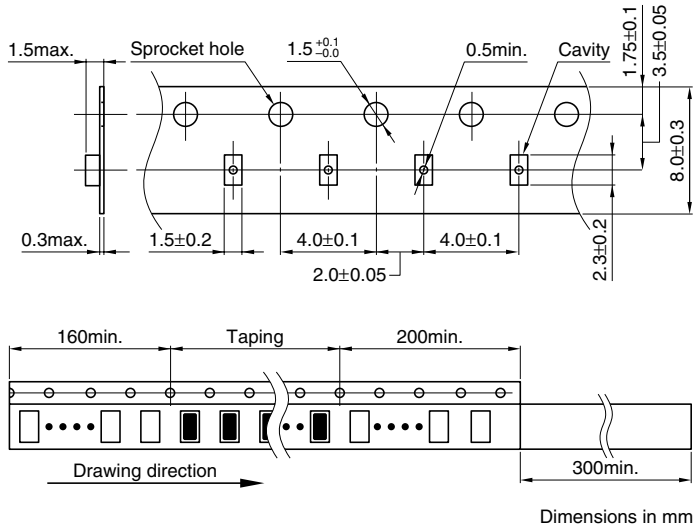

• All specifications are subject to change without notice.

SMD Inductors(Coils) For Power Line(Multilayer, Magnetic Shielded)

Conformity to RoHS Directive

MLZ Series MLZ2012

The MLZ Series is a line of multilayer choke coils for decoupling power circuits.

The MLZ2012-W Series, a line of the MLZ Series, has increased its DC superimposition characteristics by up to 250%* compared with existing products through the use of TDK's proprietary ferrite material technology.

Also available is the MLZ2012-L Series. This series has lowered its resistance by up to 50% compared with existing products through the adoption of a new ferrite material and dense electrodes. This series includes the E6 Series, which handles 1.0 to 15 μ H, hence it is extremely useful in the power-supply design of low-voltage circuits.

FEATURES

- The W Series (IDC UP type) is a line of products that have achieved the industry's best* DC superimposition characteristics.
* According to research conducted in August 2010.
- The L Series (Low-resistance type) has lowered its resistance by up to 50% compared with existing products.
- The D Series (High frequency type) is a line of decoupling coil products for high frequencies. It can handle higher noise frequencies.
- With its wider inductance range (0.1 to 47 μ H) and the addition of the E6 Series, this series can satisfy a wide variety of requirements.

APPLICATIONS

Modules such as digital cellular phone and camera module, Net-books, note PCs, DSCs, DVCs, video games, portable memory audio devices, navigation systems, PNDs, TVs, W-LANs, solid state drives

SPECIFICATIONS

Operating temperature range	-55 to +125°C [including its own temperature rise]
Storage temperature range	-55 to +125°C

RECOMMENDED SOLDERING CONDITION REFLOW SOLDERING

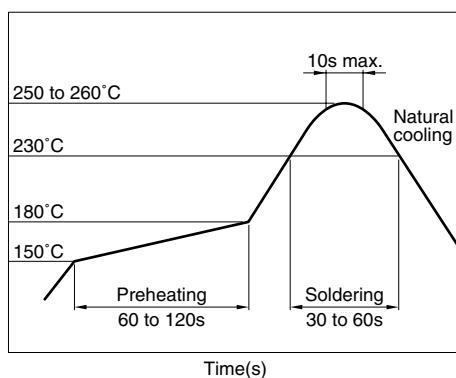

- Conformity to RoHS Directive: This means that, in conformity with EU Directive 2002/95/EC, lead, cadmium, mercury, hexavalent chromium, and specific bromine-based flame retardants, PBB and PBDE, have not been used, except for exempted applications.

- Please contact our Sales office when your application is considered the following:
The device's failure or malfunction may directly endanger human life (e.g. application for automobile/aircraft/medical/nuclear power devices, etc.)

- All specifications are subject to change without notice.

PRODUCT IDENTIFICATION

MLZ	2012	A	1R0	W	T
(1)	(2)	(3)	(4)	(5)	(6)

(1) Series name

(2) Dimensions L×W

2012	2.0×1.25mm
------	------------

(3) Management symbol

(4) Inductance value

R10	0.1 μ H
1R0	1.0 μ H
100	10.0 μ H

(5) Types of characteristics

D	High frequency type
W	IDC-UP type
L	Low-resistance type

(6) Packaging style

T	Taping [reel]
---	---------------

PACKAGING STYLE AND QUANTITIES

Packaging style	Thickness T(mm)	Quantity
Taping	0.85	4000 pieces/reel
	1.25	2000 pieces/reel

HANDLING AND PRECAUTIONS

- Before soldering, be sure to preheat components.
The preheating temperature should be set so that the temperature difference between the solder temperature and product temperature does not exceed 150°C.
- After mounting components onto the printed circuit board, do not apply stress through board bending or mishandling.
- The inductance value may change due to magnetic saturation if the current exceeds the rated maximum.
- Do not expose the inductors to stray magnetic fields.
- Avoid static electricity discharge during handling.
- When hand soldering, apply the soldering iron to the printed circuit board only. Temperature of the iron tip should not exceed 350°C. Soldering time should not exceed 3 seconds.

SHAPES AND DIMENSIONS/RECOMMENDED PC BOARD PATTERN

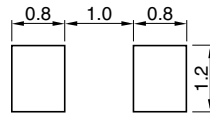
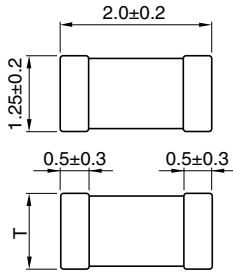

Dimensions in mm

T(Thickness)	Weight(mg)
0.85±0.2	10
1.25±0.2	14

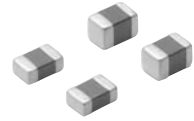

ELECTRICAL CHARACTERISTICS

Classification	Part No.	Inductance (μH)	Inductance tolerance	Thickness (mm)	Test frequency L (MHz)	Test current L (mA)	Self-resonant frequency (MHz)typ.	DC resistance (Ω)±30%	Rated current*1 (mA)	Rated current*2 (mA)
High frequency type	MLZ2012DR10DT	0.10	±20%	0.85	25	1.0	500	0.07	1000	1150
	MLZ2012DR22DT	0.22	±20%	0.85	25	1.0	330	0.13	800	900
	MLZ2012DR47DT	0.47	±20%	1.25	25	1.0	230	0.18	550	700
	MLZ2012A1R0WT	1.00	±20%	0.85	10	1.0	160	0.10	280	900
	MLZ2012A1R5WT	1.50	±20%	0.85	10	1.0	140	0.13	250	750
	MLZ2012A2R2WT	2.20	±20%	0.85	10	1.0	120	0.15	210	650
IDC-UP type	MLZ2012A3R3WT	3.30	±20%	0.85	10	1.0	90	0.34	200	450
	MLZ2012M4R7WT	4.70	±20%	0.85	2	0.1	70	0.30	180	500
	MLZ2012M6R8WT	6.80	±20%	1.25	2	0.1	60	0.40	160	400
	MLZ2012M100WT	10.0	±20%	1.25	2	0.1	50	0.47	150	350
	MLZ2012M150WT	15.0	±20%	1.25	2	0.1	40	0.95	120	250
	MLZ2012M220WT	22.0	±20%	1.25	2	0.1	35	2.00	60	220
	MLZ2012M330WT	33.0	±20%	1.25	2	0.1	28	2.60	55	190
	MLZ2012M470WT	47.0	±20%	1.25	2	0.1	20	3.70	50	170
	MLZ2012N1R0LT	1.00	±20%	0.85	2	0.1	160	0.06	220	1150
	MLZ2012N1R5LT	1.50	±20%	0.85	2	0.1	140	0.10	190	900
Low-resistance type	MLZ2012N2R2LT	2.20	±20%	0.85	2	0.1	120	0.12	170	800
	MLZ2012N3R3LT	3.30	±20%	0.85	2	0.1	90	0.15	130	750
	MLZ2012N4R7LT	4.70	±20%	0.85	2	0.1	70	0.18	130	600
	MLZ2012N6R8LT	6.80	±20%	0.85	2	0.1	60	0.25	110	550
	MLZ2012N100LT	10.0	±20%	1.25	2	0.1	50	0.30	110	500
	MLZ2012N150LT	15.0	±20%	1.25	2	0.1	40	0.47	90	350

*1 Current assumed when inductance ratio has decreased by 50% max..

*2 Current assumed when temperature has risen to 20°C max. (reference value). The maximum operating temperature at this time is 105°C.

• Test equipment

Inductance: Ag4294A-16034G

TYPICAL ELECTRICAL CHARACTERISTICS

INDUCTANCE vs. FREQUENCY CHARACTERISTICS

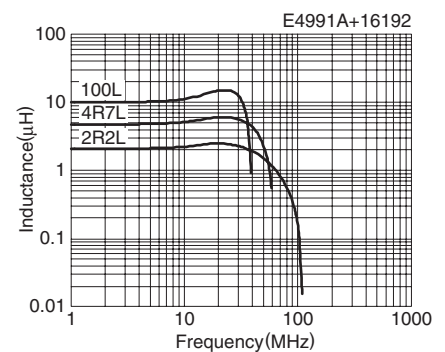
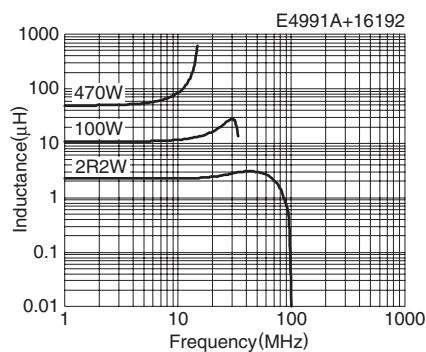
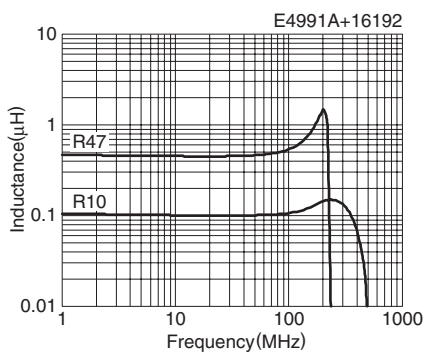

• All specifications are subject to change without notice.

TYPICAL ELECTRICAL CHARACTERISTICS IMPEDANCE vs. FREQUENCY CHARACTERISTICS

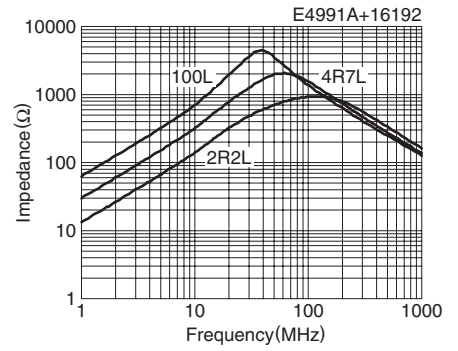
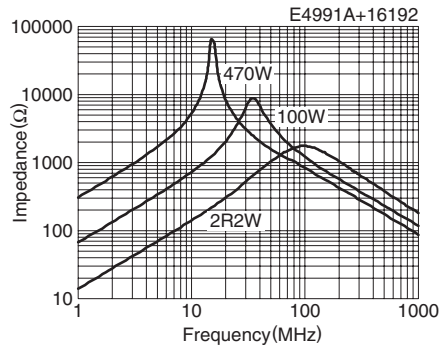
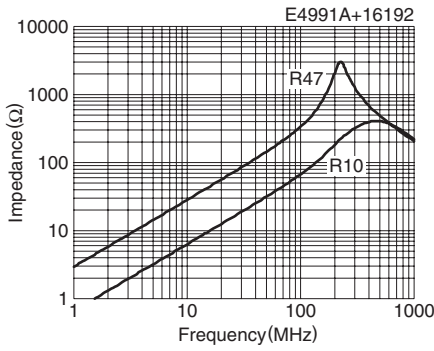

INDUCTANCE CHANGE vs. DC SUPERPOSITION CHARACTERISTICS

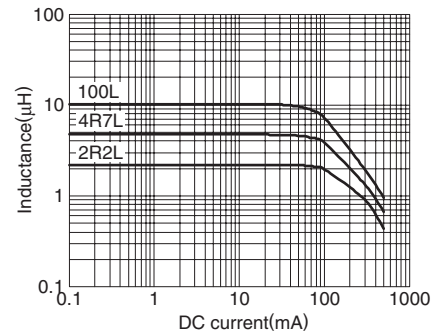
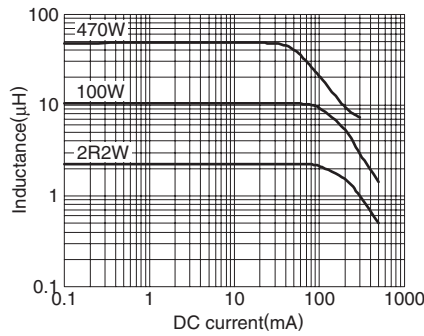
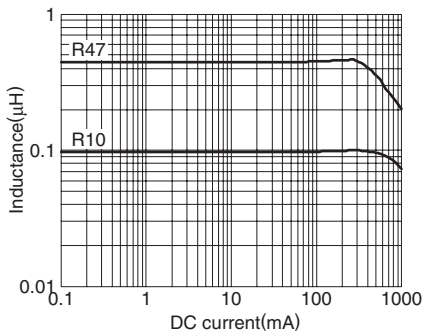

TEMPERATURE CHARACTERISTICS

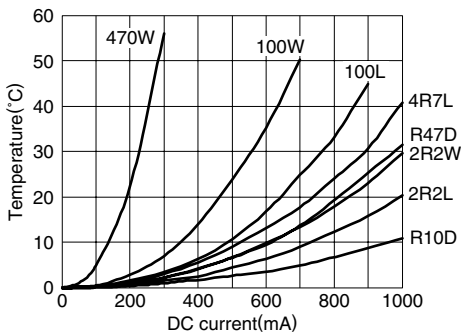

• All specifications are subject to change without notice.

PACKAGING STYLES REEL DIMENSIONS

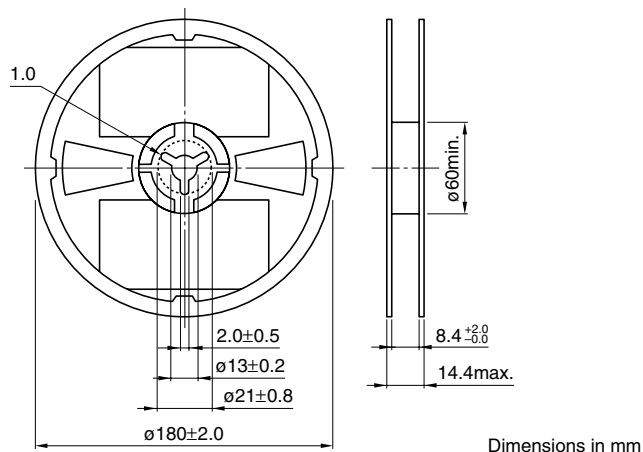

TAPE DIMENSIONS

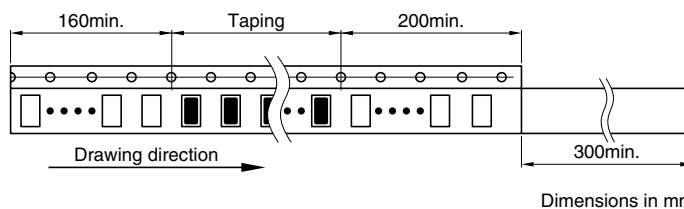
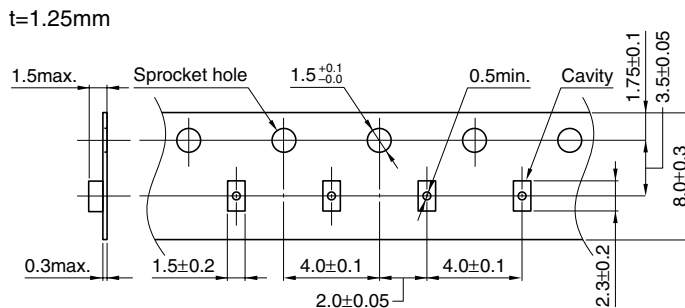
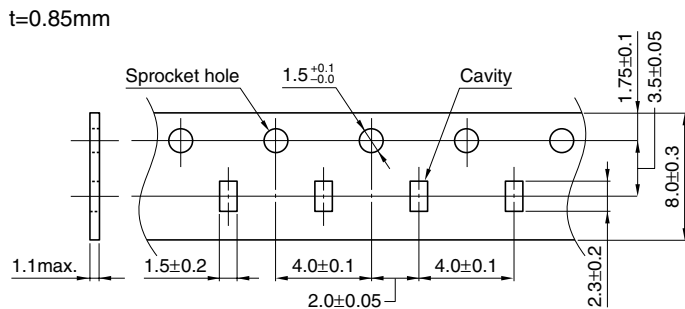

• All specifications are subject to change without notice.